



# SOSPENSIONI "K"

## SUSPENSIONS "K" / "K" FEDERUNG

### LE SOSPENSIONI "K" A BALESTRE PARABOLICHE

La gamma K del gruppo ADR rappresenta la più semplice e versatile soluzione nel campo delle sospensioni meccaniche.

Tutte le articolazioni della sospensione e le cerniere delle barre di reazione sono realizzate con boccole elastiche coniche che assicurano la massima affidabilità con la minima manutenzione.

I supporti di attacco al telaio del veicolo sono molto corti e rigidi, per ridurre al minimo le reazioni torsionali specialmente nelle curve.

L'elevata modularità dei componenti consente di realizzare soluzioni costruttive che si adattano alla maggior parte delle esigenze dei costruttori senza costringerli a gestire un enorme magazzino di componenti.

#### La gamma K comprende:

- Sospensioni monoasse da 5 a 12 ton
- Sospensioni tandem da 10 a 24 ton
- Sospensioni tridem da 24 a 36 ton

Con passo da 910 a 1850 mm e balestre a 2, 3 e 4 foglie paraboliche con larghezza da 76, 80 e 100 mm.

Le serie di sospensioni riportate nelle pagine seguenti sono contraddistinte dalle sigle KA, KD, KE, KB, KW e rappresentano soluzioni costruttive e campi di utilizzo differenti:

**KA e KD:** sospensioni a balestre paraboliche di larghezza 80 e 100 mm, schema semplificato per macchine agricole.

**KE e KB:** sospensioni a balestre paraboliche di larghezza 76 e 100 mm, con bielle di reazione, per rimorchi medi e pesanti e velocità d'impiego oltre 40 km/h.

**KW:** soluzione heavy-duty della serie KB, con balestre di larghezza 100 mm e struttura rinforzata.

#### Precauzioni

Le altezze delle sospensioni riportate in questo catalogo sono relative alla configurazione con carico nullo (A) e all'assetto con carico massimo (B) e si intendono sempre per veicoli orizzontali.

Qualora l'assetto del veicolo non fosse orizzontale (ad esempio semirimorchio) l'inclinazione del telaio influenza il comportamento della sospensione sia nel caso di tandem che di tridem, poiché l'escursione del bilancere ne risulta limitata e, in caso di percorsi accidentati, esso può urtare contro il longherone del telaio. In tal caso occorre valutare con precisione l'inclinazione del telaio del veicolo a pieno carico e compensare il dislivello tra i supporti della sospensione introducendo degli spessori tra le balestre e i corpi asse.

A tale scopo sono disponibili distanziali modulari da 30 mm.

L'applicazione del tridem è inoltre molto delicata per la distribuzione dei carichi tra i vari assi del veicolo: in tal caso sia il primo che il secondo asse devono essere adeguatamente spessorati per evitare che il carico eccessivo su un asse comprometta la sicurezza del veicolo e produca un'usura anomala dei pneumatici.

La valutazione dell'assetto corretto deve essere fatta necessariamente caso per caso. Particolare attenzione è necessaria quando uno degli assi è autosterzante: in tal caso è opportuno consultare l'ufficio tecnico ADR.



### PARABOLIC SPRING SUSPENSIONS RANGE "K"

K by ADR is the most simplest and efficient mechanical suspension unit on the market.

All the linkages are supported by adjustable rubber tie rods for maximum reliability and minimum maintenance.

All the brackets for assembly to the chassis of the vehicle are short and rigid in order to reduce torsion reactions when cornering.

The high modularity meets all the requirements of the vehicles of manufacturers, without the need to store large stocks of spares.

#### The range K includes:

- Single suspensions from 5 to 12 ton
- Tandem suspensions from 10 to 24 ton
- Tridem suspension from 24 to 36 ton

Standard wheelbase from 910 to 1850 mm with 2, 3 or 4 leaf parabolic springs 76, 80 and 100 mm wide.

The following pages show the range KA, KD, KE, KB, KW with the following features:

**KA and KD:** parabolic spring 80 and 100 mm wide, simplified version for agricultural machinery.

**KE and KB:** parabolic spring suspension, 76 and 100 mm wide, with torque arms, to fit medium and heavy trailers at speed over 40 km/h.

**KW:** is the heavy-duty version of KB range, with 100 wide springs.

#### Warning

In this catalogue both the unladen (A) and laden height (B) are marked. These heights always refer to a horizontal vehicle.

On semitrailers the angle of the chassis plays an important part on both tandem and tridem suspensions, reducing the equalizer movement, causing the equalizer to strike the frame in uneven road conditions. In this case the slope of the laden chassis must be accurately evaluated and packing pieces must be added to the spring seats. Standard 30 mm spacers are available.

Alternatively a tapered spacer can be welded between the hanger bracket and the main frame: tapered spacers are not standard pieces and are not supplied with the kits.

Care is needed with the tridem, because the angle must be compensated on three brackets: only an accurate calculation of the required packings assures the right distribution of weight on the axles and long life of tyres.

Further attention is required if one or more of the axles is a self steering unit. Please don't hesitate to ask our technical department for details.

### STEUERUNGSSYSTEME DER HYDRAULISCHEN FEDERUNG

Die Serie K der Gruppe ADR ist die einfachste und vielseitigste Lösung im Bereich der mechanischen Aufhängungen.

Alle Gelenke der Aufhängung und die Scharniere der Reaktionsstreben bestehen aus elastischen Kegelbuchsen, die maximale Zuverlässigkeit bei zugleich minimalem Wartungsbedarf garantieren.

Die Halterungen für die Befestigung am Fahrzeugrahmen sind sehr kurz und starr, um die Torsionsreaktionen vor allem in Kurven auf ein Minimum zu reduzieren.

Die ausgeprägte Modularität der Bauteile erlaubt konstruktionstechnische Lösungen, die den größten Teil der Bedürfnisse der Hersteller abdecken, ohne enorme Lagerbestände führen zu müssen.

#### Die Serie K umfasst:

- Einachsen-Federungen für 5 bis 12 t
- Tandem-Federungen für 10 bis 24 t
- Tridem-Federungen für 24 bis 36 t

Mit Achsabstand von 910 bis 1850 mm und Blattfedern mit 2, 3 oder 4 Parabelblättern, Breite 76, 80 und 100mm.

Die folgenden Seiten zeigen die kompletten KA, KD, KE, KB und KW Bauweisen der Federaggregate:

**KA und KD:** Federaggregate mit 80 und 100 mm breiten Parabelfedern, vereinfachtes Schema für Landmaschinen.

**KE und KB:** Federaggregate mit 76 und 100 mm breiten Parabelfedern und Pendelarmen, für mittlere und große Anhänger und Fahrgeschwindigkeiten über 40 km/h.

**KW:** Heavy-Duty Ausführung der Baureihe KB, mit 100 mm breiten Parabelfedern und verstärktem Rahmen.

#### Vorsichtsmaßnahmen

Die in diesem Katalog aufgeführten Höhenangaben für die Aufhängungen beziehen sich auf die Konfiguration mit Belastung Null (A) sowie auf die Straßenlage mit maximaler Last (B); sie gelten stets für waagrecht stehende Fahrzeuge.

Sollte die Fahrzeuglage nicht waagrecht sein (zum Beispiel ein Satellitenaufleger), so beeinflusst die Rahmenneigung das Verhalten der Federung sowohl in der Tandem- als auch in der Tridem-Ausführung, da der Ausschlag der Schwinge begrenzt ist und letztere im Fall unebenen Bodens gegen den Längsträger des Rahmens schlagen kann.

In diesem Fall muss die Rahmenneigung des voll beladenen Fahrzeugs sorgfältig gemessen und der Höhenunterschied zwischen den Aufhängungshalterungen durch Einfügen von Passstücken zwischen die Blattfedern und die Achskörper ausgeglichen werden. Hierzu sind Abstandstücke in Modulgröße 30 mm erhältlich.

Alternativ dazu kann als Passstück ein Keil zwischen Längsträger und Aufhängungshalterung geschweißt werden: dieser Keil ist nicht im Bausatz inbegriffen.

Die Anbringung des Tridems ist aufgrund der Lastverteilung auf die einzelnen Fahrzeugachsen zudem sehr komplex: in diesem Fall müssen sowohl die erste als auch die zweite Achse angemessen mit Passstücken versehen werden, damit die übermäßige Last auf einer Achse nicht die Sicherheit des Fahrzeugs beeinträchtigt und eine anomale Reifenabnutzung verursacht.

Die Beurteilung der korrekten Fahrzeuglage muss von Fall zu Fall korrekt erfolgen.

Besondere Aufmerksamkeit ist geboten, wenn eine der Achsen selbstlenkend ist: in diesem Fall sollte die technische Abteilung von ADR hinzugezogen werden.



## SOSPENSIONI K FORNITE IN KIT

KIT FOR SUSPENSION K / AUFHÄNGUNGEN K WERDEN IM BAUSATZ GELIEFERT

### PRE MONTAGGIO DEI COMPONENTI

Le sospensioni K vengono consegnate in kit, con i gruppi meccanici pre-montati, in dettaglio:

- gruppo bilancere centrale completamente montato, con il perno centrale non serrato per agevolare le operazioni di assemblaggio al telaio del veicolo.
- bielle fisse con le boccole coniche montate e i perni non serrati.
- bielle regolabili con le boccole coniche e i terminali montati, lunghezze non regolate e perni non serrati (questa operazione deve sempre essere eseguita sul veicolo).
- viti di ritegno delle balestre montate su tutti i supporti.
- bride di ancoraggio, dadi, piastre e supporti di biella da saldare al corpo asse saranno forniti imballati a parte.

Per le istruzioni di montaggio vedere l'apposita sezione di questo catalogo.



### PRE-ASSEMBLY

The K suspensions are delivered in kits, with the pre-assembled mechanical groups, in detail:

- Rocker arm assembly with loosened hinge, to be tightened after the assembling to the chassis.
- Rigid torque arms complete with tapered bushes and loosened bolts.
- Adjustable torque arms complete with tapered bushes and end sup ports, not adjusted in length and with loosened bolts (adjusting and tightening must always be done on the trailer).
- End bolts for springs on all the supports.
- U bolts, nuts, plates and supports be welded to the axle beam will be delivered in separate package.

The instructions for assembly are in the appropriate section of this catalogue.

### VORMONTAGE DER KOMPONENTEN

Die K-Federungen werden im Bausatz mit vormontierten mechanischen Einheiten geliefert. Im Einzelnen:

- Einheit mittlere Schwinge komplett montiert, Mittelzapfen nicht angezogen zur einfacheren Montage am Fahrzeugrahmen.
- Feste Pleuelstangen mit montierten Kegelbuchsen und nicht angezogenen Zapfen.
- Verstellpleuelstangen mit montierten Kegelbuchsen und Endstücken, Länge nicht reguliert und Zapfen nicht angezogen (dieser Vorgang muss stets am Fahrzeug erfolgen).
- Rückhaltschrauben der Blattfedern an allen Halterungen montiert.
- Verankerungsbügel, Muttern, Platten und Pleuelstangenhalterungen zum Verschweißen am Achskörper werden separat verpackt geliefert.

Für die Montageanleitungen siehe den entsprechenden Katalogabschnitt.

### SOSPENSIONI PRE-ASSEMBLATE

PREASSEMBLED SUSPENSIONS / VORMONTIERTE FEDERUNGEN

#### UNA SOLUZIONE INNOVATIVA DA ADR PER LE SOSPENSIONI DELLE MACCHINE AGRICOLE

Un errore di qualche millimetro nell'allineamento degli assi o di assetto delle ruote può produrre maggiori consumi di carburante e usura precoce degli pneumatici. L'adeguata precisione nel montaggio e nella regolazione dei componenti di una sospensione può essere raggiunta solo con una strumentazione appropriata.

Per questo motivo le aziende del gruppo ADR sono state equipaggiate di esclusivi banchi-dima per consegnare ai costruttori di rimorchi le sospensioni completamente montate, già a misura secondo le sue esigenze.

Tutte le saldature con criticità strutturali, così come i montaggi meccanici più impegnativi vengono eseguiti dal personale ADR secondo le disposizioni dei tecnici che hanno seguito lo sviluppo degli assi e delle sospensioni fin dalle prime fasi di progettazione. La sovrastruttura che lega tutti i componenti della sospensione ne agevola la movimentazione durante la costruzione del veicolo e può essere agevolmente adattata al telaio.

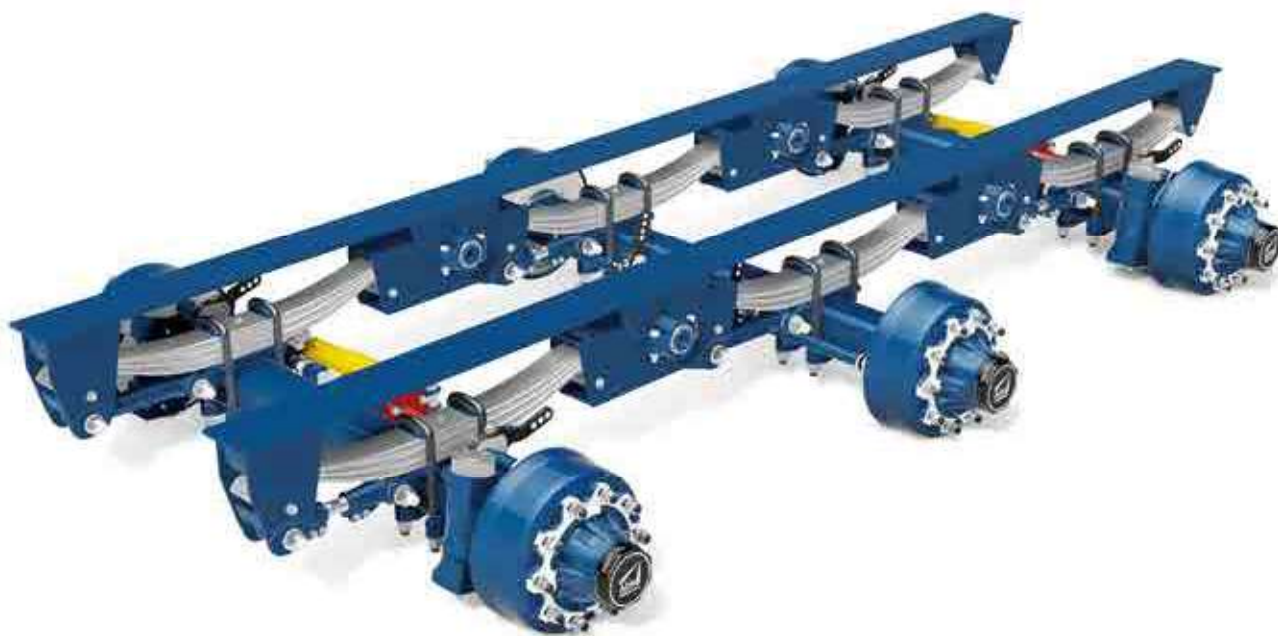

#### AN INNOVATING ADR SOLUTION FOR AGRICULTURAL MACHINERY SUSPENSIONS

If the measurement is a few millimetres out in the axle alignment or in the tyre position this can cause higher fuel consumption and early tyre wear.

The appropriate precision in assembling and adjusting a suspension components can only be obtained with a suitable equipment.

That's why ADR Group companies have been equipped with some exclusive benches so as to supply trailer manufacturers with completely assembled suspensions, already dimensioned as required.

All weldings subject to structural problems as well as the most difficult assembling operations are carried out by ADR staff according to the prescriptions of the technicians who have been following the axle and suspension development from the very beginning.

#### EINE INNOVATIVE LÖSUNG VON ADR FEDERUNGEN BEI LANDMASCHINEN

Nur ein kleiner Fehler von ein paar Millimetern bei der Ausrichtung der Achsen oder der Trimmung der Räder kann einen höheren Kraftstoffverbrauch und höheren Reifenverschleiß zur Folge haben.

Die richtige Präzision bei der Montage und der Einstellung der einzelnen Komponenten einer Federung kann nur mit der geeigneten Ausrüstung erreicht werden.

Daher sind alle Firmen der ADR-Gruppe mit exklusiven Richtbänken ausgestattet, um den Anhängerherstellern die Federungen komplett montiert zu liefern, schon auf ihre Bedürfnisse eingestellt. Alle Schweißnähte an kritischen Stellen sowie die anspruchsvollen mechanischen.

Montagen werden vom ADR - Fachpersonal durchgeführt, das sich nach den Vorgaben der Techniker richten, die vom ersten Moment an an der Entwicklung der Federungen mitgearbeitet haben. Der Oberbau, der alle Komponenten der Federung verbindet, erleichtert ihre Handhabung während der Bauphase des Fahrzeuges und kann bequem an den Fahrzeugrahmen angepasst werden.



**IDENTIFICAZIONE**  
IDENTIFICATION /  
KENNZEICHNUNG

**CODICE CLIENTE**  
Customer code  
Kunden Art.-Nr.

**LOTTO DI PRODUZIONE**  
Production lot  
Produktionsanteil

**CODICE ADR**  
ADR code  
ADR Art.-Nr.

**PORTATA (kg)**  
Capacity (kg)  
Achslast (kg)

**SITO PRODUTTIVO**  
Production site  
Produktionsstätte



**ALTEZZA DI MARCIA**  
Ride height  
Fahrhöhe

**PASSO**  
Wheelbase  
Achsabstand

**K B 2 153 B4 N 11 41**

**SOSPENSIONE PARABOLICA**  
parabolic spring  
parabolische Blattfedern

**ALTEZZA A VUOTO**  
height unladen  
Höhe unbeladen

**TIPO SOSPENSIONE**  
type of suspension  
Aufhängungstyp

**KA**  
= see page 96

**KD**  
= see page 99

**KE**  
= see page 102

**KB**  
= see page 109

**KW**  
= see page 112

**CORPO ASSE**  
axle beam  
Achskörper

**T1 = 127 mm**

**07 = 70 mm**  
**08 = 80 mm**  
**09 = 90 mm**  
**10 = 100 mm**  
**11 = 110 mm**

**12 = 120 mm**  
**13 = 130 mm**  
**15 = 150 mm**

**NUMERO DI ASSI**  
number of axles  
Anzahl der Achsen

**N = NORMALE**  
normal  
normal

**R = RIBASSATO**  
underslung  
Tieflader

**PASSO**  
wheelbase  
Achsabstand

**TIPO BALESTRA**  
type of spring - Blattfedertyp

# SOSPENSIONI "K"

## SUSPENSIONS "K" / "K" FEDERUNG

### ASSENZA DI MANUTENZIONE ORDINARIA

NO ROUTINE MAINTENANCE / KEINE ROUTINEMÄSSIGE WARTUNG

PERCHÉ UNA NUOVA SERIE DI SOSPENSIONI?  
LA SOLUZIONE PER RESTARE "A SPASSO" CON I TEMPI.

La nuova generazione di SOSPENSIONI MECCANICHE KA con portate da 4 Ton a 16 Ton valorizza i punti forza delle sospensioni ed integra le innovazioni tecnologiche richieste da mercato:

- Velocità di utilizzo sempre maggiori.
- Materiali più leggeri con prestazioni elevate e sicure.
- Costi e tempi di fermo per la manutenzione ridotti o azzerati.
- Sospensioni più robuste per tutte le tipologie di terreni e di facile installazione.

WHY A NEW SUSPENSION SERIES?  
THE SOLUTION TO KEEP UP WITH THE TIMES.

The new generation of KA MECHANICAL SUSPENSIONS with capacities from 4 tonnes to 16 tonnes increases the strengths of suspensions and incorporates the technological innovations demanded by the market:

- Ever-faster speeds of use.
- Use of lighter materials that allow high and safe performance
- Reduced or zero maintenance costs and downtime
- Stronger suspensions, well adapted to all types of terrain and easy to install.

WARUM EINE NEUE SERIE FEDERUNGEN?  
DIE LÖSUNG UM SPIELEND LEICHT MIT DER ZEIT ZU GEHEN.

Die neue Generation MECHANISCHER KA-FEDERUNGEN mit Tragfähigkeiten von 4 bis 16 Tonnen optimiert die bestehenden Stärken der derzeitigen Federungen und integriert technologische Innovationen, um neuen Marktanforderungen zu genügen:

- Einer höheren Nutzungsgeschwindigkeit
- Der Verwendung leichterer Materialien die ein Mehr an Leistung und Sicherheit bieten,
- Reduzierten bzw. überhaupt keinen Wartungskosten und Ausfallzeiten,
- Einer robusteren Federung, die für alle Arten von Gelände gut geeignet und leicht zu installieren ist.

**Balestre a profilo parabolico: - peso + carico.**  
Parabolic leaf springs. - weight + load.  
Parabelfedern. Gewicht + Ladekapazität.

**Assenza di manutenzione ordinaria.**  
No routine maintenance.  
Keine routinemäßige Wartung.

**Struttura in acciaio fuso di elevata precisione ed importante robustezza.**

High precision and very robust cast steel structure.

Körper aus Stahlguss von hoher Präzision und erheblicher Widerstandsfähigkeit.

**Ancoraggio dell'assale.**  
Axle anchorage.  
Verankerung der Achsen.

type **KA** 80<sup>mm</sup> wide  
**KA** SUSPENSION  
MAINTENANCE FREE

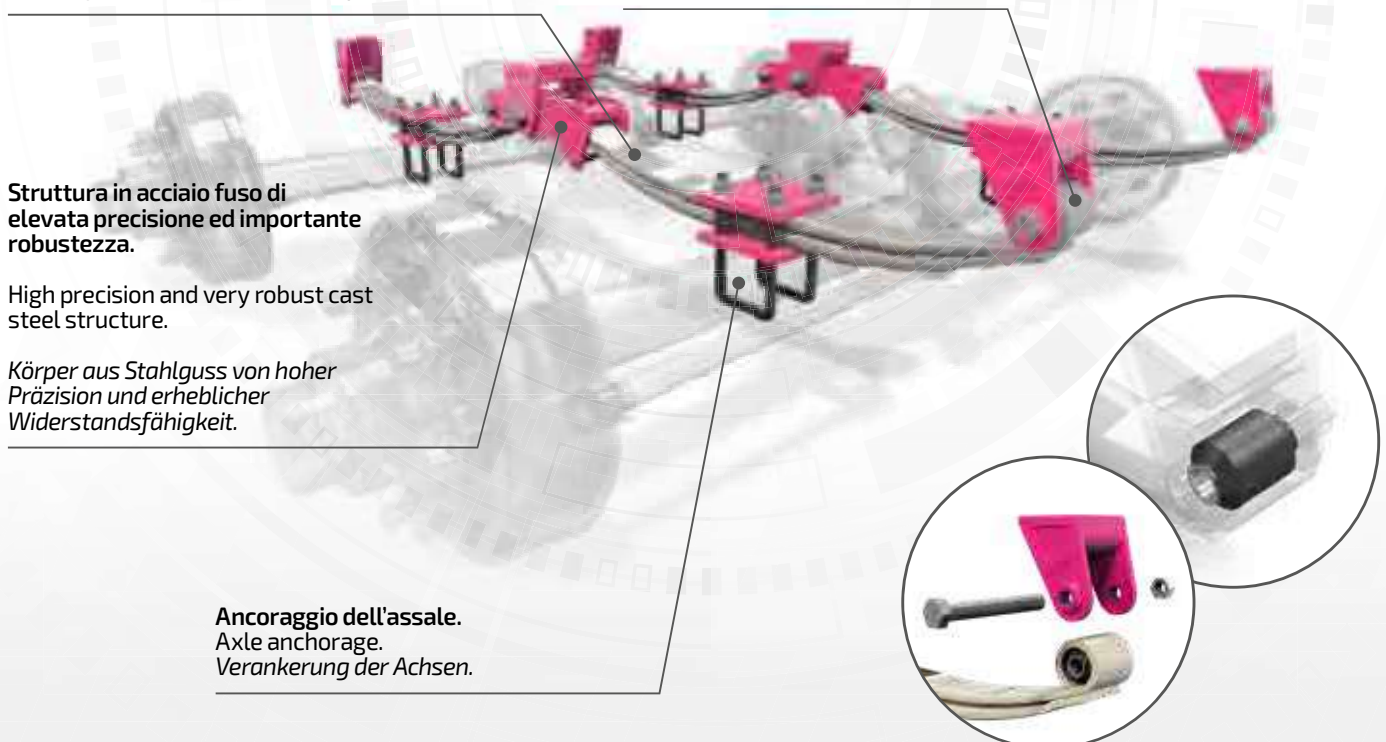

# KA\_SUSPENSION



## SOSPENSIONE MONOASSE SENZA MANUTENZIONE

MAINTENANCE-FREE SINGLE SUSPENSION  
WARTUNGSFREIE EINZELNE FEDERUNG

type **KA** 80 mm wide

**KA** SUSPENSION  
MAINTENANCE FREE

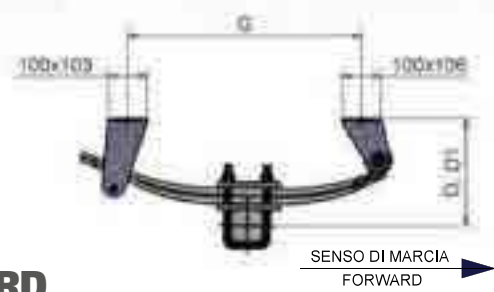

### STANDARD

C	E	G	H	Q	D	D1	LF	EA	CD
kg	mm	mm	mm	mm	mm	mm		mm	
5 000	-	530	-	70	242	227	RP80G416	-	KA1000C5N0724
				80	247	232			KA1000C5N0825
7 000	-	600	-	70	270	256	RP80G412	-	KA1000C1N0727
				80	275	261			KA1000C1N0828
				90	280	266			KA1000C1N0928
8 000	-	810	-	70	280	256	RP80G413	-	KA1000C3N0728
				80	285	261			KA1000C3N0829
				90	290	266			KA1000C3N0929

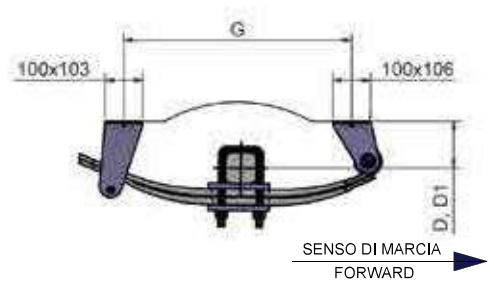

### RIBASSATO / UNDERSLUNG / TIEFLADER

C	E	G	H	Q	D	D1	LF	EA	CD
kg	mm	mm	mm	mm	mm	mm		mm	
5 000	-	530	-	70	110	95	RP80G416	-	KA1000C5R0711
				80	105	90			KA1000C5R0811
7 000	-	600	-	70	128	114	RP80G412	-	KA1000C1R0713
				80	123	109			KA1000C1R0812
				90	118	104			KA1000C1R0912
8 000	-	810	-	70	129	105	RP80G413	-	KA1000C3R0713
				80	124	100			KA1000C3R0812
				90	119	95			KA1000C3R0912

- C = PORTATA / CAPACITY / TRAGFÄHIGKEIT
- E = PASSO / WHEEL BASE / ACHSABSTAND
- G = DISTANZA APPOGGI 1 / BRACKET DISTANCE 1 / AUFHÄNGUNGSABSTAND 1
- H = DISTANZA APPOGGI 2 / BRACKET DISTANCE 2 / AUFHÄNGUNGSABSTAND 2
- Q = TIPO ASSALE (LATO QUADRO) / AXLE TYPE (SQUARE BEAM) / ACHSENTYP (VKT)
- D = ALTEZZA A VUOTO / HEIGHT WHEN EMPTY / BETRIEBSHÖHE-LEER
- D1 = ALTEZZA SOTTO CARICO / HEIGHT LOADED / BETRIEBSHÖHE-BELADEN
- LF = TIPO BALESTRA / LEAF SPRING / FEDERTYP
- EA = PASSO BILANCIERE / ROCKER LENGTH / LÄNGE AUSGLEICHWIEGE
- CD = CODICE ORDINE / ORDER CODE / BESTELLN.R.

# SOSPENSIONI "K"

## SUSPENSIONS "K" / "K" FEDERUNG

### SOSPENSIONE MONOASSE SENZA MANUTENZIONE

MAINTENANCE-FREE SINGLE SUSPENSION  
WARTUNGSFREIE EINZELNE FEDERUNG

type **KA** 80 mm wide

**KA** SUSPENSION  
MAINTENANCE FREE



### STANDARD

C	E	G	H	Q	D	D1	LF	EA	CD
kg	mm	mm	mm	mm	mm	mm		mm	
5 000	-	575	-	70	242	227	RP80G416	-	KA1000C5N0724T
				80	247	232			KA1000C5N0825T
7 000	-	645	-	70	270	256	RP80G412	-	KA1000C1N0727T
				80	275	261			KA1000C1N0828T
				90	280	266			KA1000C1N0928T
8 000	-	855	-	70	280	256	RP80G413	-	KA1000C3N0728T
				80	285	261			KA1000C3N0829T
				90	290	266			KA1000C3N0929T

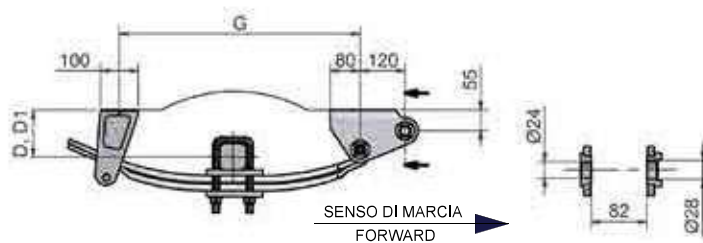

### RIBASSATO / UNDERSLUNG / TIEFLADER

C	E	G	H	Q	D	D1	LF	EA	CD
kg	mm	mm	mm	mm	mm	mm		mm	
5 000	-	575	-	70	110	95	RP80G416	-	KA1000C5R0711T
				80	105	90			KA1000C5R0811T
7 000	-	645	-	70	128	114	RP80G412	-	KA1000C1R0713T
				80	123	109			KA1000C1R0812T
				90	118	104			KA1000C1R0912T
8 000	-	855	-	70	129	105	RP80G413	-	KA1000C3R0713T
				80	124	100			KA1000C3R0812T
				90	119	95			KA1000C3R0912T

C = PORTATA / CAPACITY / TRAGFÄHIGKEIT

E = PASSO / WHEEL BASE / ACHSABSTAND

G = DISTANZA APPOGGI 1 / BRACKET DISTANCE 1 / AUFHÄNGUNGSABSTAND 1

H = DISTANZA APPOGGI 2 / BRACKET DISTANCE 2 / AUFHÄNGUNGSABSTAND 2

Q = TIPO ASSALE (LATO QUADRO) / AXLE TYPE (SQUARE BEAM) / ACHSENTYP (VKT)

D = ALTEZZA A VUOTO / HEIGHT WHEN EMPTY / BETRIEBSHÖHE-LEER

D1 = ALTEZZA SOTTO CARICO / HEIGHT LOADED / BETRIEBSHÖHE-BELADEN

LF = TIPO BALESTRA / LEAF SPRING / FEDERTYP

EA = PASSO BILANCIERE / ROCKER LENGTH / LÄNGE AUSGLEICHWIEGE

CD = CODICE ORDINE / ORDER CODE / BESTELLN.R.





## SOSPENSIONE TANDEM SENZA MANUTENZIONE

MAINTENANCE-FREE TANDEM SUSPENSION  
WARTUNGSFREI TANDEM SUSPENSION

type **KA** 80<sup>mm</sup> wide

**KA** SUSPENSION  
MAINTENANCE FREE

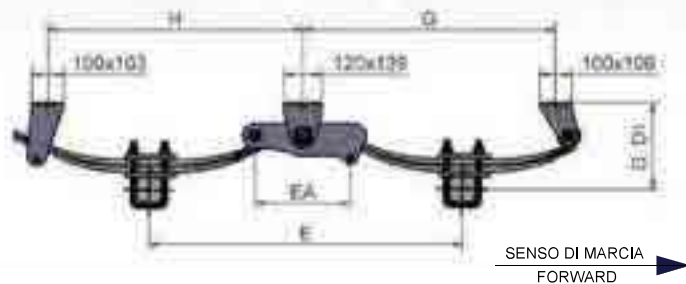

### STANDARD

C	E	G	H	Q	D	D1	LF	EA	CD
kg	mm	mm	mm	mm	mm	mm		mm	
10 000	910	717	725	70	242	227	RP80G416	310	KA2091C5N0724
				80	247	232			KA2091C5N0825
	1060	787	795	70	242	227	RP80G416	470	KA2106C5N0724
				80	247	232			KA2106C5N0825
14 000	990	797	805	80	275	261	RP80G412	310	KA2099C1N0828
				90	280	266			KA2099C1N0928
	1150	877	885	80	275	261	RP80G412	470	KA2115C1N0828
				90	280	266			KA2115C1N0928
16 000	1200	1007	1015	90	290	266	RP80G413	310	KA2120C3N0929
				100	300	276			KA2120C3N1030
	1350	1077	1085	90	290	266	RP80G413	470	KA2135C3N0929
				100	300	276			KA2135C3N1030

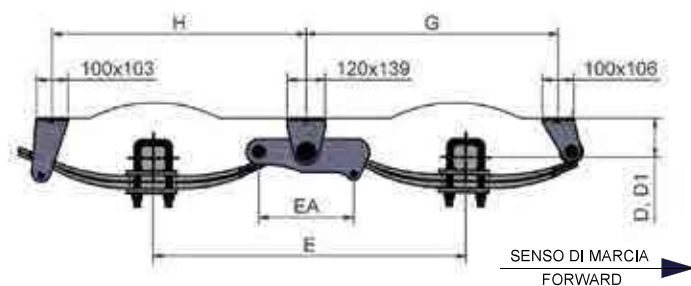

### RIBASSATO / UNDERSLUNG / TIEFLADER

C	E	G	H	Q	D	D1	LF	EA	CD
kg	mm	mm	mm	mm	mm	mm		mm	
10 000	910	717	725	70	110	95	RP80G416	310	KA2091C5R0711
				80	105	90			KA2091C5R0811
14 000	990	797	805	80	123	109	RP80G412	310	KA2099C1R0812
				90	118	104			KA2099C1R0912
16 000	1200	1007	1015	80	124	100	RP80G413	310	KA2120C3R0812
				90	119	95			KA2120C3R0912

C = PORTATA / CAPACITY / TRAGFÄHIGKEIT

E = PASSO / WHEEL BASE / ACHSABSTAND

G = DISTANZA APPOGGI 1 / BRACKET DISTANCE 1 / AUFHÄNGUNGSABSTAND 1

H = DISTANZA APPOGGI 2 / BRACKET DISTANCE 2 / AUFHÄNGUNGSABSTAND 2

Q = TIPO ASSALE (LATO QUADRO) / AXLE TYPE (SQUARE BEAM) / ACHSENTYP (VKT)

D = ALTEZZA A VUOTO / HEIGHT WHEN EMPTY / BETRIEBSHÖHE-LEER

D1 = ALTEZZA SOTTO CARICO / HEIGHT LOADED / BETRIEBSHÖHE-BELADEN

LF = TIPO BALESTRA / LEAF SPRING / FEDERTYP

EA = PASSO BILANCIERE / ROCKER LENGTH / LÄNGE AUSGLEICHWIEGE

CD = CODICE ORDINE / ORDER CODE / BESTELLN.

### MONOASSE CON BALESTRA PARABOLICA

SINGLE SUSPENSION WITH PARABOLIC SPRING  
EINZELACHSAGGREGAT MIT PARABELFEDERN

type **KD** 100<sup>mm</sup> wide

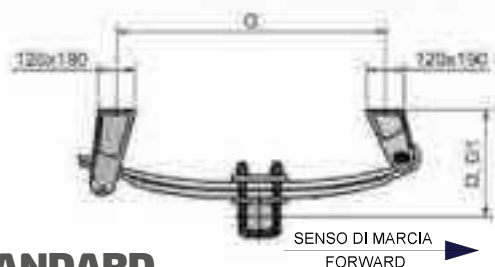

#### STANDARD

C	E	G	H	Q	D	D1	LF	EA	CD
kg	mm	mm	mm	mm	mm	mm		mm	
10500	-	870	-	90	341	323	RP100G115	-	KD1000D2N0934
				100	346	328			KD1000D2N1035
				120	361	343			KD1000D2N1237

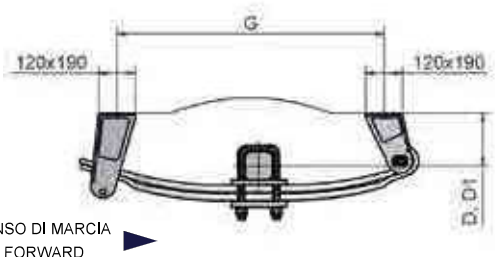

#### RIBASSATO / UNDERSLUNG / TIEFLADER

C	E	G	H	Q	D	D1	LF	EA	CD
kg	mm	mm	mm	mm	mm	mm		mm	
10500	-	870	-	90	167	149	RP100G115	-	KD1000D2R0916
				100	162	144			KD1000D2R1015
				120	147	129			KD1000D2R1214

C = PORTATA / CAPACITY / TRAGFÄHIGKEIT

E = PASSO / WHEEL BASE / ACHSABSTAND

G = DISTANZA APPOGGI 1 / BRACKET DISTANCE 1 / AUFHÄNGUNGSABSTAND 1

H = DISTANZA APPOGGI 2 / BRACKET DISTANCE 2 / AUFHÄNGUNGSABSTAND 2

Q = TIPO ASSALE (LATO QUADRO) / AXLE TYPE (SQUARE BEAM) / ACHSENTYP (VKT)

D = ALTEZZA A VUOTO / HEIGHT WHEN EMPTY / BETRIEBSHÖHE-LEER

D1 = ALTEZZA SOTTO CARICO / HEIGHT LOADED / BETRIEBSHÖHE-BELADEN

LF = TIPO BALESTRA / LEAF SPRING / FEDERTYP

EA = PASSO BILANCIERE / ROCKER LENGTH / LÄNGE AUSGLEICHWIEGE

CD = CODICE ORDINE / ORDER CODE / BESTELLNr.



## MONOASSE CON BALESTRA PARABOLICA

SINGLE SUSPENSION WITH PARABOLIC SPRING  
EINZELACHSAGGREGAT MIT PARABELFEDERN

type **KD 100** mm wide



### STANDARD

C	E	G	H	Q	D	D1	LF	EA	CD
kg	mm	mm	mm	mm	mm	mm		mm	
10500	-	925	-	90	341	323	RP100G115	-	KD1000D2N0934T
				100	346	328			KD1000D2N1035T
				120	361	343			KD1000D2N1237T

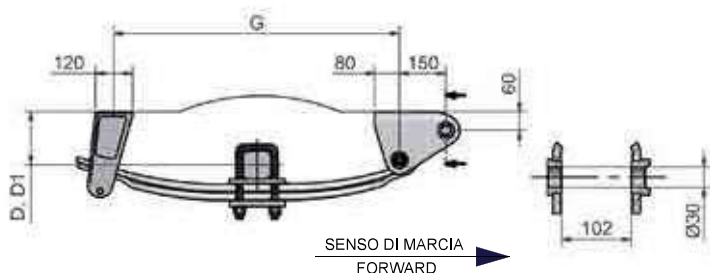

### RIBASSATO / UNDERSLUNG / TIEFLADER

C	E	G	H	Q	D	D1	LF	EA	CD
kg	mm	mm	mm	mm	mm	mm		mm	
10500	-	925	-	90	167	149	RP100G115	-	KD1000D2R0916T
				100	162	144			KD1000D2R1015T
				120	147	129			KD1000D2R1214T

C = PORTATA / CAPACITY / TRAGFÄHIGKEIT

E = PASSO / WHEEL BASE / ACHSABSTAND

G = DISTANZA APPOGGI 1 / BRACKET DISTANCE 1 / AUFHÄNGUNGSABSTAND 1

H = DISTANZA APPOGGI 2 / BRACKET DISTANCE 2 / AUFHÄNGUNGSABSTAND 2

Q = TIPO ASSALE (LATO QUADRO) / AXLE TYPE (SQUARE BEAM) / ACHSENTYP (VKT)

D = ALTEZZA A VUOTO / HEIGHT WHEN EMPTY / BETRIEBSHÖHE-LEER

D1 = ALTEZZA SOTTO CARICO / HEIGHT LOADED / BETRIEBSHÖHE-BELADEN

LF = TIPO BALESTRA / LEAF SPRING / FEDERTYP

EA = PASSO BILANCIERE / ROCKER LENGTH / LÄNGE AUSGLEICHWIEGE

CD = CODICE ORDINE / ORDER CODE / BESTELLN.R.

# SOSPENSIONI "K"

## SUSPENSIONS "K" / "K" FEDERUNG

AXLES & STUBAXLES

TEKNOAX

FITTINGS

BOGGIES

SUSPENSIONS "K"

HYDRAULIC SUSP.

AIR SUSPENSIONS

### TANDEM CON BALESTRA PARABOLICA

TANDEM SUSPENSION WITH PARABOLIC SPRING  
DOPPELACHSAGGREGAT MIT PARABELFEDERN

type **KD** 100<sup>mm</sup> wide

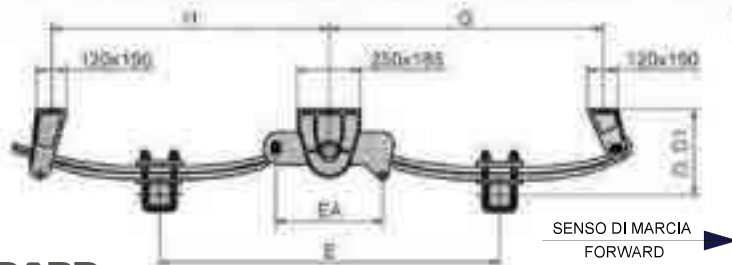

### STANDARD

C	E	G	H	Q	D	D1	LF	EA	CD
kg	mm	mm	mm	mm	mm	mm		mm	
21000	1350	1087	1100	100	346	328	RP100G115	420	KD2136D2N1035
				120	361	343			KD2136D2N1237
	1480	1152	1165	100	346	328	RP100G115	550	KD2150D2N1035
				120	361	343			KD2150D2N1237
	1570	1202	1215	100	346	328	RP100G115	630	KD2157D2N1035
				120	361	343			KD2157D2N1237

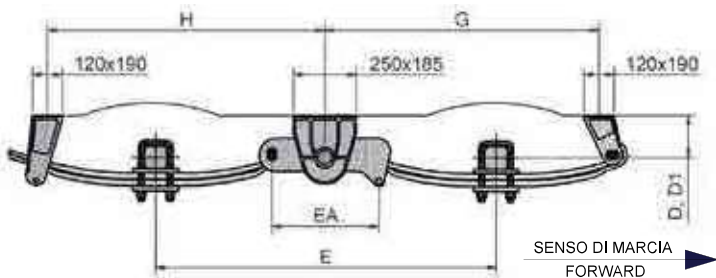

### RIBASSATO / UNDERSLUNG / TIEFLADER

C	E	G	H	Q	D	D1	LF	EA	CD
kg	mm	mm	mm	mm	mm	mm		mm	
21000	1350	1087	1100	100	162	144	RP100G115	420	KD2136D2R1015
				120	147	129			KD2136D2R1214
	1480	1152	1165	100	162	144	RP100G115	550	KD2150D2R1015
				120	147	129			KD2150D2R1214
	1570	1202	1215	100	162	144	RP100G115	630	KD2157D2R1015
				120	147	129			KD2157D2R1214

C = PORTATA / CAPACITY / TRAGFÄHIGKEIT

E = PASSO / WHEEL BASE / ACHSABSTAND

G = DISTANZA APPOGGI 1 / BRACKET DISTANCE 1 / AUFHÄNGUNGSABSTAND 1

H = DISTANZA APPOGGI 2 / BRACKET DISTANCE 2 / AUFHÄNGUNGSABSTAND 2

Q = TIPO ASSALE (LATO QUADRO) / AXLE TYPE (SQUARE BEAM) / ACHSENTYP (VKT)

D = ALTEZZA A VUOTO / HEIGHT WHEN EMPTY / BETRIEBSHÖHE-LEER

D1 = ALTEZZA SOTTO CARICO / HEIGHT LOADED / BETRIEBSHÖHE-BELADEN

LF = TIPO BALESTRA / LEAF SPRING / FEDERTYP

EA = PASSO BILANCIERE / ROCKER LENGTH / LÄNGE AUSGLEICHWIEGE

CD = CODICE ORDINE / ORDER CODE / BESTELLN.R.



## MONOASSE CON BALESTRA PARABOLICA

SINGLE SUSPENSION WITH PARABOLIC SPRING  
EINZELACHSAGGREGAT MIT PARABELFEDERN

type **KE** 76<sup>mm</sup><sub>wide</sub>

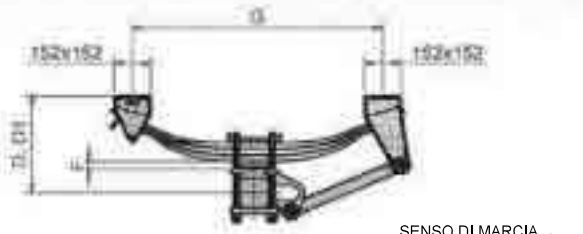

SENSO DI MARCIA  
FORWARD



### STANDARD

C	E	G	J	Q	D	D1	LF		EA	CD		
							LF1-3	LF2				
kg	mm	mm	mm	mm	mm	mm			mm			
8000	-	825	-	90	315	280	3 x 23 x 1000	-	-	KE1000B5N0932		
				100							KE1000B5N1032	
				120							KE1000B5N1232	
				Ø127							KE1000B5NT132	
10000	-	990	-	90	365	315	3 x 25 x 1150	-	-	KE1000B7N0937		
				100						KE1000B7N1037		
				120						KE1000B7N1237		
				Ø127						KE1000B7NT137		
		1030	-	-	-	90	370	323	3 x 25 x 1197	-	-	KE1000B1N0938
						100						KE1000B1N1038
						120						KE1000B1N1238
						Ø127						KE1000B1NT138
12000	-	825	-	100	340	313	4 x 23 x 1000	-	-	KE1000B8N1034		
				120						KE1000B8N1234		
				130						KE1000B8N1334		
				Ø127						KE1000B8NT134		
		1030	-	-	-	100	400	340	4 x 25 x 1197	-	-	KE1000B4N1040
						120						KE1000B4N1240
						130						KE1000B4N1340
						Ø127						KE1000B4NT140

(F) Disponibili distanziali di 30mm per aumentare l'altezza di marcia (D, D1)

(F) Available spacers of 30mm to increase the ride height (D, D1)

(F) 30 mm Abstandstück verfügbar für Fahrhöhe vermehren (D, D1)

C = PORTATA / CAPACITY / TRAGFÄHIGKEIT

E = PASSO / WHEEL BASE / ACHSABSTAND

G = DISTANZA APPOGGI 1-3 / BRACKET DISTANCE 1-3 / AUFHÄNGUNGSABSTAND 1-3

J = DISTANZA APPOGGI 2 / BRACKET DISTANCE 2 / AUFHÄNGUNGSABSTAND 2

Q = TIPO ASSALE (LATO QUADRO) / AXLE TYPE (SQUARE BEAM) / ACHSENTYP (VKT)

D = ALTEZZA A VUOTO / HEIGHT WHEN EMPTY / BETRIEBSHÖHE-LEER

D1 = ALTEZZA SOTTO CARICO / HEIGHT LOADED / BETRIEBSHÖHE-BELADEN

LF1-3 = TIPO BALESTRA 1-3 / LEAF SPRING 1-3 / FEDERTYP 1-3

LF2 = TIPO BALESTRA 2 / LEAF SPRING 2 / FEDERTYP 2

EA = PASSO BILANCIERE / ROCKER LENGTH / LÄNGE AUSGLEICHWIEGE

CD = CODICE ORDINE / ORDER CODE / BESTELLN.R.

F = DISTANZIALE / SPACER / ABSTANDSTÜCK

# SOSPENSIONI "K"

## SUSPENSIONS "K" / "K" FEDERUNG

AXLES & STUBAXLES

### TANDEM CON BALESTRA PARABOLICA

TANDEM SUSPENSION WITH PARABOLIC SPRING  
DOPPELACHSAGGREGAT MIT PARABELFEDERN

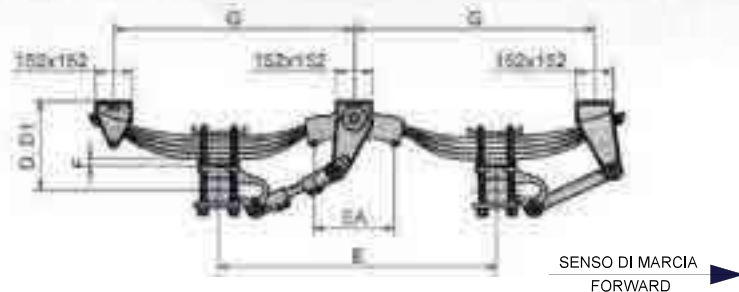

### STANDARD

C	E	G	J	Q	D	D1	LF		EA	CD
							LF1-3	LF2		
kg	mm	mm	mm	mm	mm	mm			mm	
16 000	1145	990	-	90	315	280	3 x 23 x 1000	-	336	KE2115B5N0932
				100						KE2115B5N1032
				120						KE2115B5N1232
				Ø127						KE2115B5NT132
	1200	1045	-	90	315	280	3 x 23 x 1000	-	400	KE2120B5N0932
				100						KE2120B5N1032
				120						KE2120B5N1232
				Ø127						KE2120B5NT132
	1310	1075	-	90	315	280	3 x 23 x 1000	-	490	KE2131B5N0932
				100						KE2131B5N1032
				120						KE2131B5N1232
				Ø127						KE2131B5NT132
20 000	1310	1155	-	90	365	315	3 x 25 x 1150	-	336	KE2131B7N0937
				100						KE2131B7N1037
				120						KE2131B7N1237
				Ø127						KE2131B7NT137
	1360	1205	-	90	370	323	3 x 25 x 1197	-	336	KE2136B1N0938
				100						KE2136B1N1038
				120						KE2136B1N1238
				Ø127						KE2136B1NT138
	1400	1225	-	90	370	322	3 x 25 x 1197	-	400	KE2140B1N0938
				100						KE2140B1N1038
				120						KE2140B1N1238
				Ø127						KE2140B1NT138
	1525	1285	-	90	370	322	3 x 25 x 1197	-	490	KE2153B1N0938
				100						KE2153B1N1038
				120						KE2153B1N1238
				Ø127						KE2153B1NT138

TEKNOAX

FITTINGS

BOGGIES

SUSPENSIONS "K"

HYDRAULIC SUSP.

AIR SUSPENSIONS

(F) Disponibili distanziali di 30mm per aumentare l'altezza di marcia (D, D1)

(F) Available spacers of 30mm to increase the ride height (D, D1)

(F) 30 mm Abstandstück verfügbar für Fahrhöhe vermehren (D, D1)

C = PORTATA / CAPACITY / TRAGFÄHIGKEIT

E = PASSO / WHEEL BASE / ACHSABSTAND

G = DISTANZA APPOGGI 1-3 / BRACKET DISTANCE 1-3 / AUFHÄNGUNGSABSTAND 1-3

J = DISTANZA APPOGGI 2 / BRACKET DISTANCE 2 / AUFHÄNGUNGSABSTAND 2

Q = TIPO ASSALE (LATO QUADRO) / AXLE TYPE (SQUARE BEAM) / ACHSENTYP (VKT)

D = ALTEZZA A VUOTO / HEIGHT WHEN EMPTY / BETRIEBSHÖHE-LEER

D1 = ALTEZZA SOTTO CARICO / HEIGHT LOADED / BETRIEBSHÖHE-BELADEN

LF1-3 = TIPO BALESTRA 1-3 / LEAF SPRING 1-3 / FEDERTYP 1-3

LF2 = TIPO BALESTRA 2 / LEAF SPRING 2 / FEDERTYP 2

EA = PASSO BILANCIERE / ROCKER LENGTH / LÄNGE AUSGLEICHWIEGE

CD = CODICE ORDINE / ORDER CODE / BESTELLNr.

F = DISTANZIALE / SPACER / ABSTANDSTÜCK



**TANDEM CON BALESTRA PARABOLICA**  
 TANDEM SUSPENSION WITH PARABOLIC SPRING  
 DOPPELACHSAGGREGAT MIT PARABELFEDERN

type **KE** 76<sup>mm</sup> wide

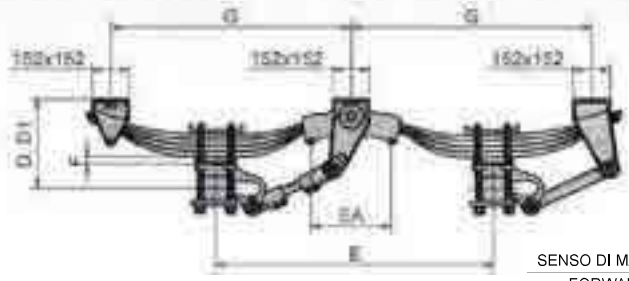

SENSO DI MARCIA  
FORWARD

**STANDARD**

C kg	E mm	G mm	J mm	Q mm	D mm	D1 mm	LF		EA mm	CD	
							LF1-3	LF2			
24 000	1145	990	-	100	340	313	4 x 23 x 1000	-	336	KE2115B8N1034	
				120						KE2115B8N1234	
				130						KE2115B8N1334	
				Ø127						KE2115B8NT134	
	1200	1045	-	100	340	313	4 x 23 x 1000	-	400	KE2120B8N1034	
				120						KE2120B8N1234	
				130						KE2120B8N1334	
				Ø127						KE2120B8NT134	
	1310	1080	-	100	340	313	4 x 23 x 1000	-	490	KE2131B8N1034	
				120						KE2131B8N1234	
				130						KE2131B8N1334	
				Ø127						KE2131B8NT134	
	1360	1205	-	100	400	340	4 x 25 x 1197	-	336	KE2136B4N1040	
				120						KE2136B4N1240	
				130						KE2136B4N1340	
				Ø127						KE2136B4NT140	
	1400	1225	-	100	400	340	4 x 25 x 1197	-	400	KE2140B4N1040	
				120						KE2140B4N1240	
				130						KE2140B4N1340	
				Ø127						KE2140B4NT140	
	1525	1285	-	100	400	340	4 x 25 x 1197	-	490	KE2153B4N1040	
				120						KE2153B4N1240	
				130						KE2153B4N1340	
				Ø127						KE2153B4NT140	
	1360	1400	-	-	100	395	370	3 x 32 x 1140	-	-	KE2...B3... (!)
					120						
					130						
					Ø127						

(F) Disponibili distanziali di 30mm per aumentare l'altezza di marcia (D, D1)

(F) Available spacers of 30mm to increase the ride height (D, D1)

(F) 30 mm Abstandstück verfügbar für Fahrhöhe vermehren (D, D1)

- C = PORTATA / CAPACITY / TRAGFÄHIGKEIT
- E = PASSO / WHEEL BASE / ACHSABSTAND
- G = DISTANZA APPOGGI 1-3 / BRACKET DISTANCE 1-3 / AUFHÄNGUNGSABSTAND 1-3
- J = DISTANZA APPOGGI 2 / BRACKET DISTANCE 2 / AUFHÄNGUNGSABSTAND 2
- Q = TIPO ASSALE (LATO QUADRO) / AXLE TYPE (SQUARE BEAM) / ACHSENTYP (VKT)
- D = ALTEZZA A VUOTO / HEIGHT WHEN EMPTY / BETRIEBSHÖHE-LEER
- D1 = ALTEZZA SOTTO CARICO / HEIGHT LOADED / BETRIEBSHÖHE-BELADEN
- LF1-3 = TIPO BALESTRA 1-3 / LEAF SPRING 1-3 / FEDERTYP 1-3
- LF2 = TIPO BALESTRA 2 / LEAF SPRING 2 / FEDERTYP 2
- EA = PASSO BILANCIERE / ROCKER LENGTH / LÄNGE AUSGLEICHWIEGE
- CD = CODICE ORDINE / ORDER CODE / BESTELLN.R.
- F = DISTANZIALE / SPACER / ABSTANDSTÜCK

# SOSPENSIONI "K"

## SUSPENSIONS "K" / "K" FEDERUNG

AXLES & STUBAXLES

### TRIDEM CON BALESTRA PARABOLICA

TRI-AXLE SUSPENSION WITH PARABOLIC SPRING  
DREIACHSAGGREGAT MIT PARABELFEDERN

type **KE** 76 mm wide

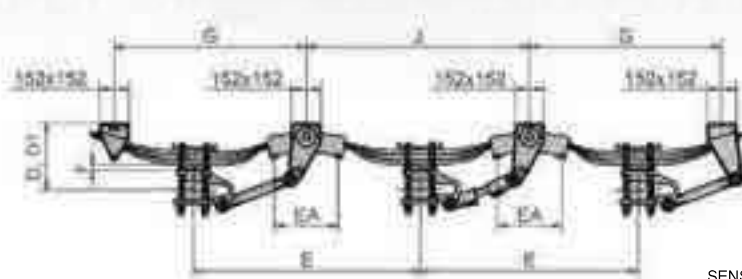

SENSO DI MARCIA  
FORWARD



### STANDARD

C	E	G	J	Q	D	D1	LF		EA	CD
							LF1-3	LF2		
kg	mm	mm	mm	mm	mm	mm			mm	
24000	1145	990	1145	90	315	280	3 x 23 x 1000	3 x 23 x 972	336	KE3115B5N0932
				100						KE3115B5N1032
				120						KE3115B5N1232
				Ø127						KE3115B5NT132
	1200	1045	1200	90	315	280	3 x 23 x 1000	3 x 23 x 972	400	KE3120B5N0932
				100						KE3120B5N1032
				120						KE3120B5N1232
				Ø127						KE3120B5NT132
	1310	1075	1310	90	315	280	3 x 23 x 1000	3 x 23 x 972	490	KE3131B5N0932
				100						KE3131B5N1032
				120						KE3131B5N1232
				Ø127						KE3131B5NT132
30000	1360	1205	1360	90	370	323	3 x 25 x 1197	3 x 25 x 1175	336	KE3136B1N0938
				100						KE3136B1N1038
				120						KE3136B1N1238
				Ø127						KE3136B1NT138
	1400	1225	1400	90	370	323	3 x 25 x 1197	3 x 25 x 1175	400	KE3140B1N0938
				100						KE3140B1N1038
				120						KE3140B1N1238
				Ø127						KE3140B1NT138
	1525	1285	1525	90	370	323	3 x 25 x 1197	3 x 25 x 1175	490	KE3153B1N0938
				100						KE3153B1N1038
				120						KE3153B1N1238
				Ø127						KE3153B1NT138

TEKNOAX

FITTINGS

BOGGIES

SUSPENSIONS "K"

HYDRAULIC SUSP.

AIR SUSPENSIONS

(F) Disponibili distanziali di 30mm per aumentare l'altezza di marcia (D, D1)

(F) Available spacers of 30mm to increase the ride height (D, D1)

(F) 30 mm Abstandstück verfügbar für Fahrhöhe vermehren (D, D1)

C = PORTATA / CAPACITY / TRAGFÄHIGKEIT

E = PASSO / WHEEL BASE / ACHSABSTAND

G = DISTANZA APPOGGI 1-3 / BRACKET DISTANCE 1-3 / AUFHÄNGUNGSABSTAND 1-3

J = DISTANZA APPOGGI 2 / BRACKET DISTANCE 2 / AUFHÄNGUNGSABSTAND 2

Q = TIPO ASSALE (LATO QUADRO) / AXLE TYPE (SQUARE BEAM) / ACHSENTYP (VKT)

D = ALTEZZA A VUOTO / HEIGHT WHEN EMPTY / BETRIEBSHÖHE-LEER

D1 = ALTEZZA SOTTO CARICO / HEIGHT LOADED / BETRIEBSHÖHE-BELADEN

LF1-3 = TIPO BALESTRA 1-3 / LEAF SPRING 1-3 / FEDERTYP 1-3

LF2 = TIPO BALESTRA 2 / LEAF SPRING 2 / FEDERTYP 2

EA = PASSO BILANCIERE / ROCKER LENGTH / LÄNGE AUSGLEICHWIEGE

CD = CODICE ORDINE / ORDER CODE / BESTELLN.R.

F = DISTANZIALE / SPACER / ABSTANDSTÜCK





**TRIDEM CON BALESTRA PARABOLICA**  
 TRI-AXLE SUSPENSION WITH PARABOLIC SPRING  
 DREIACHSAGGREGAT MIT PARABELFEDERN

type **KE** 76<sup>mm</sup> wide

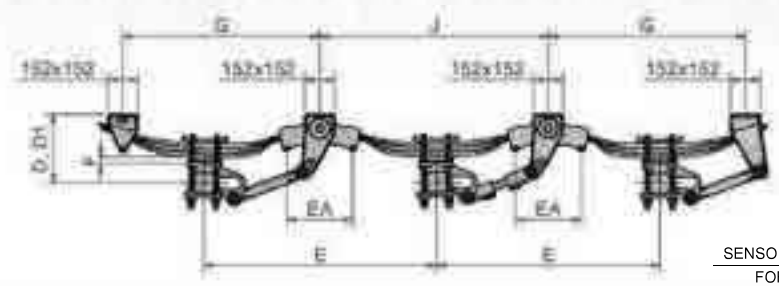

SENSO DI MARCIA  
 FORWARD

**STANDARD**

C	E	G	J	Q	D	D1	LF		EA	CD
							LF1-3	LF2		
kg	mm	mm	mm	mm	mm	mm			mm	
36 000	1145	990	1145	100	340	313	4 x 23 x 1000	4 x 23 x 975	336	KE3115B8N1034
				120						KE3115B8N1234
				130						KE3115B8N1334
				Ø127						KE3115B8NT134
	1200	1045	1200	100	340	313	4 x 23 x 1000	4 x 23 x 975	400	KE3120B8N1034
				120						KE3120B8N1234
				130						KE3120B8N1334
				Ø127						KE3120B8NT134
	1310	1075	1310	100	340	313	4 x 23 x 1000	4 x 23 x 975	490	KE3131B8N1034
				120						KE3131B8N1234
				130						KE3131B8N1334
				Ø127						KE3131B8NT134
	1360	1205	1360	100	400	340	4 x 25 x 1197	4 x 25 x 1175	336	KE3136B4N1040
				120						KE3136B4N1240
				130						KE3136B4N1340
				Ø127						KE3136B4NT140
	1400	1225	1400	100	400	340	4 x 25 x 1197	4 x 25 x 1175	400	KE3140B4N1040
				120						KE3140B4N1240
				130						KE3140B4N1340
				Ø127						KE3140B4NT140
	1525	1285	1525	100	400	340	4 x 25 x 1197	4 x 25 x 1175	490	KE3153B4N1040
				120						KE3153B4N1240
				130						KE3153B4N1340
				Ø127						KE3153B4NT140
	1525	1285	1525	120	424	384	5 x 25 x 1187	5 x 25 x 1176	490	KE3153C4N1242
				130						KE3153C4N1342
				Ø127						KE3153C4NT142
	1360 1400 1525	-	-	100	395	370	3 x 32 x 1140	-	-	KE3...B3... (!)
				120						
				130						
				Ø127						

(F) Disponibili distanziali di 30mm per aumentare l'altezza di marcia (D, D1)  
 (F) Available spacers of 30mm to increase the ride height (D, D1)  
 (F) 30 mm Abstandstück verfügbar für Fahrhöhe vermehren (D, D1)

# SOSPENSIONI "K"

## SUSPENSIONS "K" / "K" FEDERUNG

### TANDEM CON BALESTRA PARABOLICA

TANDEM SUSPENSION WITH PARABOLIC SPRING  
DOPPELACHSAGGREGAT MIT PARABELFEDERN

type **KE** 76 mm wide

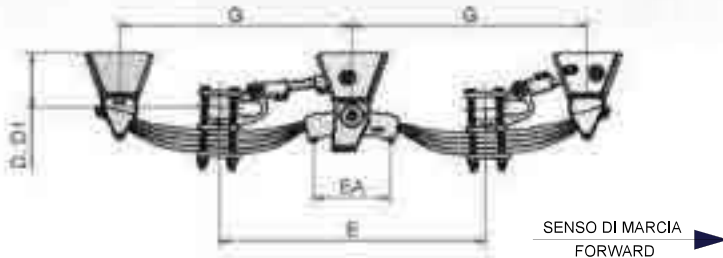

### RIBASSATO / UNDERSLUNG / TIEFLADER

C	E	G	J	Q	D	D1	LF		EA	CD
							LF1-3	LF2		
kg	mm	mm	mm	mm	mm	mm			mm	
16 000	1145	1015	-	90	230	195	3 x 23 x 1000	-	336	KE2115B5R092...
				100						KE2115B5R102...
				120						KE2115B5R122...
	1200	1040	-	90	230	195	3 x 23 x 1000	-	400	KE2120B5R092...
				100						KE2120B5R102...
				120						KE2120B5R122...
	1310	1095	-	90	230	195	3 x 23 x 1000	-	490	KE2131B5R092...
				100						KE2131B5R102...
				120						KE2131B5R122...
20 000	1360	1210	-	100	290	243	3 x 25 x 1197	-	336	KE2136B1R102...
				120						KE2136B1R122...
	1400	1230	-	100	290	243	3 x 25 x 1197	-	400	KE2140B1R102...
				120						KE2140B1R122...
	1525	1280	-	100	290	243	3 x 25 x 1197	-	490	KE2153B1R102...
				120						KE2153B1R122...
24 000	1145	1015	-	120	230	195	4 x 23 x 1000	-	336	KE2115B8R122...
				130						KE2115B8R132...
	1200	1040	-	120	230	195	4 x 23 x 1000	-	400	KE2120B8R122...
				130						KE2120B8R132...
	1310	1095	-	120	230	195	4 x 23 x 1000	-	490	KE2131B8R122...
				130						KE2131B8R132...
	1360	1210	-	120	290	230	4 x 25 x 1197	-	336	KE2136B4R122...
				130						KE2136B4R132...
	1400	1230	-	120	290	230	4 x 25 x 1197	-	400	KE2140B4R122...
				130						KE2140B4R132...
	1525	1280	-	120	290	230	4 x 25 x 1197	-	490	KE2153B4R122...
				130						KE2153B4R132...

C = PORTATA / CAPACITY / TRAGFÄHIGKEIT

E = PASSO / WHEEL BASE / ACHSABSTAND

G = DISTANZA APPOGGI 1-3 / BRACKET DISTANCE 1-3 / AUFHÄNGUNGSABSTAND 1-3

J = DISTANZA APPOGGI 2 / BRACKET DISTANCE 2 / AUFHÄNGUNGSABSTAND 2

Q = TIPO ASSALE (LATO QUADRO) / AXLE TYPE (SQUARE BEAM) / ACHSENTYP (VKT)

D = ALTEZZA A VUOTO / HEIGHT WHEN EMPTY / BETRIEBSHÖHE-LEER

D1 = ALTEZZA SOTTO CARICO / HEIGHT LOADED / BETRIEBSHÖHE-BELADEN

LF1-3 = TIPO BALESTRA 1-3 / LEAF SPRING 1-3 / FEDERTYP 1-3

LF2 = TIPO BALESTRA 2 / LEAF SPRING 2 / FEDERTYP 2

EA = PASSO BILANCIERE / ROCKER LENGTH / LÄNGE AUSGLEICHWIEGE

CD = CODICE ORDINE / ORDER CODE / BESTELLN.R.

F = DISTANZIALE / SPACER / ABSTANDSTÜCK



**TRIDEM CON BALESTRA PARABOLICA**  
 TRI-AXLE SUSPENSION WITH PARABOLIC SPRING  
 DREIACHSAGGREGAT MIT PARABELFEDERN

type **KE** 76 mm wide

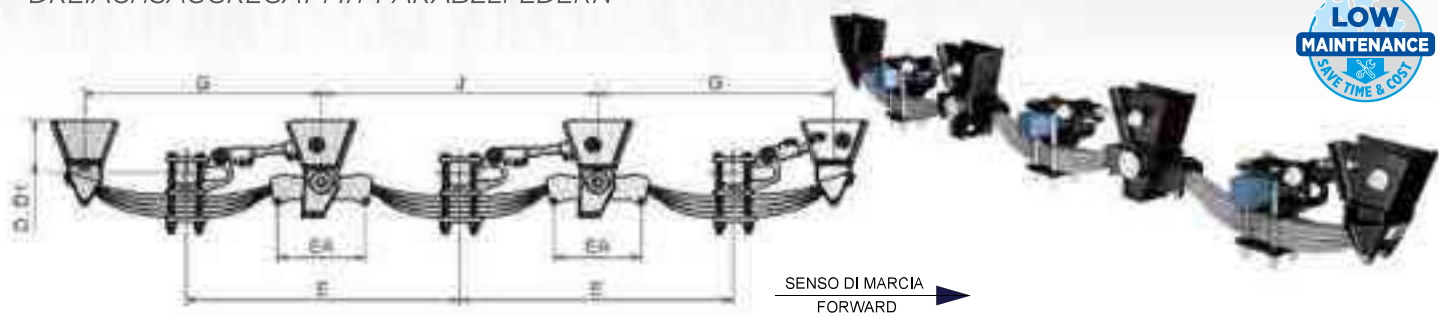

**RIBASSATO / UNDERSLUNG / TIEFLADER**

C	E	G	J	Q	D	D1	LF		EA	CD
							LF1-3	LF2		
kg	mm	mm	mm	mm	mm	mm			mm	
24 000	1145	1015	1155	90	230	195	3 x 23 x 1000	3 x 23 x 972	336	KE3115B5R092...
				100						KE3115B5R102...
				120						KE3115B5R122...
	1200	1040	1210	90	230	195	3 x 23 x 1000	3 x 23 x 972	400	KE3120B5R092...
				100						KE3120B5R102...
				120						KE3120B5R122...
	1310	1095	1310	90	230	195	3 x 23 x 1000	3 x 23 x 972	490	KE3131B5R092...
				100						KE3131B5R102...
				120						KE3131B5R122...
30 000	1360	1210	1365	100	290	243	3 x 25 x 1197	3 x 25 x 1175	336	KE3136B1R102...
				120						KE3136B1R122...
	1400	1230	1400	100	290	243	3 x 25 x 1197	3 x 25 x 1175	400	KE3140B1R102...
				120						KE3140B1R122...
	1525	1280	1525	100	290	243	3 x 25 x 1197	3 x 25 x 1175	490	KE3153B1R102...
				120						KE3153B1R122...
36 000	1145	1015	1155	120	230	195	4 x 23 x 1000	4 x 23 x 975	336	KE3115B8R122...
				130						KE3115B8R132...
	1200	1040	1210	120	230	195	4 x 23 x 1000	4 x 23 x 975	400	KE3120B8R122...
				130						KE3120B8R132...
	1310	1095	1310	120	230	195	4 x 23 x 1000	4 x 23 x 975	490	KE3131B8R122...
				130						KE3131B8R132...
	1360	1210	1365	120	290	230	4 x 25 x 1197	4 x 25 x 1175	336	KE3136B4R122...
				130						KE3136B4R132...
	1400	1230	1400	120	290	230	4 x 25 x 1197	4 x 25 x 1175	400	KE3140B4R122...
				130						KE3140B4R132...
	1525	1280	1525	120	290	230	4 x 25 x 1197	4 x 25 x 1175	490	KE3153B4R122...
				130						KE3153B4R132...

C = PORTATA / CAPACITY / TRAGFÄHIGKEIT  
 E = PASSO / WHEEL BASE / ACHSABSTAND  
 G = DISTANZA APPOGGI 1-3 / BRACKET DISTANCE 1-3 / AUFHÄNGUNGSABSTAND 1-3  
 J = DISTANZA APPOGGI 2 / BRACKET DISTANCE 2 / AUFHÄNGUNGSABSTAND 2  
 Q = TIPO ASSALE (LATO QUADRO) / AXLE TYPE (SQUARE BEAM) / ACHSENTYP (VKT)  
 D = ALTEZZA A VUOTO / HEIGHT WHEN EMPTY / BETRIEBSHÖHE-LEER  
 D1 = ALTEZZA SOTTO CARICO / HEIGHT LOADED / BETRIEBSHÖHE-BELADEN  
 LF1-3 = TIPO BALESTRA 1-3 / LEAF SPRING 1-3 / FEDERTYP 1-3  
 LF2 = TIPO BALESTRA 2 / LEAF SPRING 2 / FEDERTYP 2  
 EA = PASSO BILANCIERE / ROCKER LENGTH / LÄNGE AUSGLEICHWIEGE  
 CD = CODICE ORDINE / ORDER CODE / BESTELLN.R.  
 F = DISTANZIALE / SPACER / ABSTANDSTÜCK

### MONOASSE CON BALESTRA PARABOLICA

SINGLE SUSPENSION WITH PARABOLIC SPRING  
EINZELACHSAGGREGAT MIT PARABELFEDERN

type **KB** 100<sup>mm</sup><sub>wide</sub>

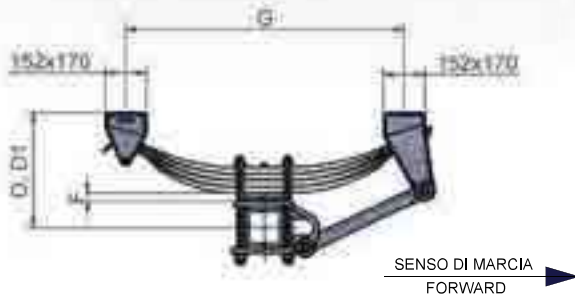

### STANDARD

C	E	G	J	Q	F	D	D1	LF 1-3	EA	CD
kg	mm	mm	mm	mm	mm	mm	mm		mm	
12000	-	1010	-	120	0	287	264	2 x 30 x 1180	-	KB1000C1N1230
					30	317	294			
				130	0	287	264	2 x 30 x 1180	-	KB1000C1N1330
					30	317	294			
14000	-	1050	-	130	0	315	285	3 x 27 x 1190	-	KB1000C2N1332
					30	345	315			
				150	0	315	285	3 x 27 x 1190	-	KB1000C2N1532
					30	345	315			
	-	1030	-	130	0	380	354	3 x 27 x 1180	-	KB1000C3N1338
					30	410	384			
				150	0	380	354	3 x 27 x 1180	-	KB1000C3N1538
					30	410	384			

(F) Disponibili distanziali di 30mm per aumentare l'altezza di marcia (D, D1)

(F) Available spacers of 30mm to increase the ride height (D, D1)

(F) 30 mm Abstandstück verfügbar für Fahrhöhe vermehren (D, D1)





## TANDEM CON BALESTRA PARABOLICA

TANDEM SUSPENSION WITH PARABOLIC SPRING  
DOPPELACHSAGGREGAT MIT PARABELFEDERN

type **KB 100** mm wide

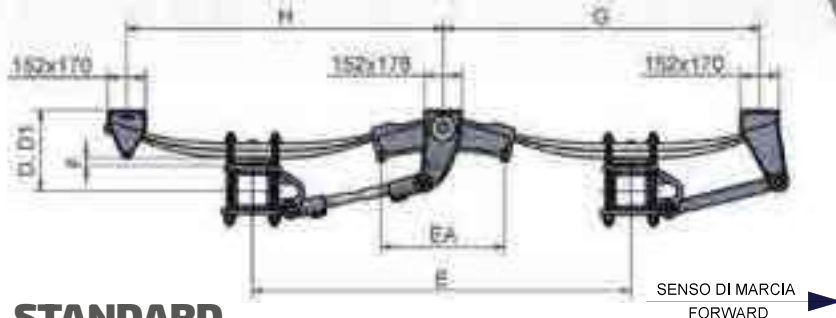

### STANDARD

C	E	G	H	Q	D	D1	LF	EA	CD
kg	mm	mm	mm	mm	mm	mm	LF1-3	mm	
24000	1360	1185	1185	130	295	272	2 x 30 x 1180	336	KB2136C1N1330
	1525	1260	1260					490	KB2153C1N1330
28000	1360	1185	1185	150	315	285	3 x 27 x 1190	336	KB2136C2N1532
	1525	1260	1260					490	KB2153C2N1532
28000	1360	1205	1205	150	385	359	3 x 27 x 1180	336	KB2136C3N1538
	1525	1285	1275					490	KB2153C3N1538

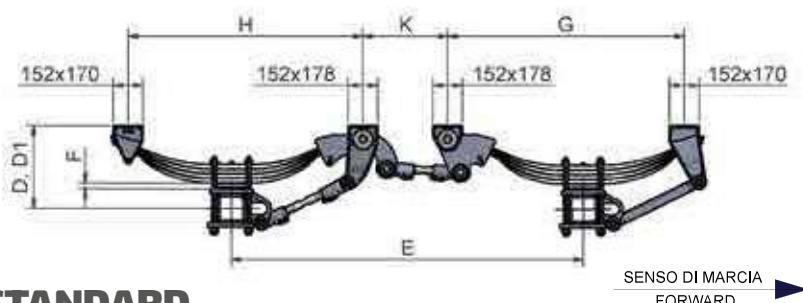

### STANDARD

C	E	G	H	K	Q	D	D1	LF	CD
kg	mm	mm	mm	mm	mm	mm	mm	LF1-3	
28000	1810	1195	1170	435	150	315	285	3 x 27 x 1190	KB218AC2N1532
28000	1810	1215	1195	435	150	385	359	3 x 27 x 1180	KB218AC3N1538

(F) Disponibili distanziali di 30mm per aumentare l'altezza di marcia (D, D1)  
 (F) Available spacers of 30mm to increase the ride height (D, D1)  
 (F) 30 mm Abstandstück verfügbar für Fahrhöhe vermehren (D, D1)

- C = PORTATA / CAPACITY / TRAGFÄHIGKEIT
- E = PASSO / WHEEL BASE / ACHSABSTAND
- G = DISTANZA APPOGGI 1-3 / BRACKET DISTANCE 1-3 / AUFHÄNGUNGSABSTAND 1-3
- J = DISTANZA APPOGGI 2 / BRACKET DISTANCE 2 / AUFHÄNGUNGSABSTAND 2
- Q = TIPO ASSALE (LATO QUADRO) / AXLE TYPE (SQUARE BEAM) / ACHSENTYP (VKT)
- D = ALTEZZA A VUOTO / HEIGHT WHEN EMPTY / BETRIEBSHÖHE-LEER
- D1 = ALTEZZA SOTTO CARICO / HEIGHT LOADED / BETRIEBSHÖHE-BELADEN
- LF1-3 = TIPO BALESTRA 1-3 / LEAF SPRING 1-3 / FEDERTYP 1-3
- LF2 = TIPO BALESTRA 2 / LEAF SPRING 2 / FEDERTYP 2
- EA = PASSO BILANCIERE / ROCKER LENGTH / LÄNGE AUSGLEICHWIEGE
- CD = CODICE ORDINE / ORDER CODE / BESTELLN.R.
- F = DISTANZIALE / SPACER / ABSTANDSTÜCK

# SOSPENSIONI "K"

## SUSPENSIONS "K" / "K" FEDERUNG

AXLES & STUBAXLES

TEKNOAX

FITTINGS

BOGGIES

SUSPENSIONS "K"

HYDRAULIC SUSP.

AIR SUSPENSIONS

### TRIDEM CON BALESTRA PARABOLICA

TRI-AXLE SUSPENSION WITH PARABOLIC SPRING  
DREIACHSAGGREGAT MIT PARABELFEDERN

type **KB** 100<sup>mm</sup><sub>wide</sub>

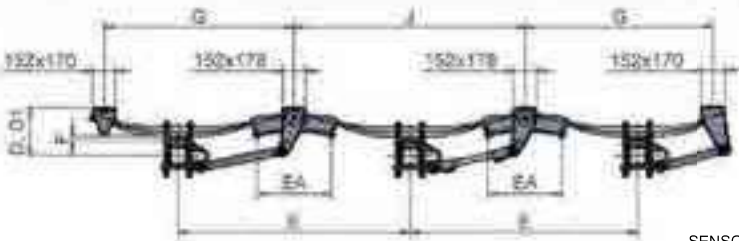

SENSO DI MARCIA  
FORWARD

### STANDARD

C	E	G	J	Q	D	D1	LF	EA	CD
kg	mm	mm	mm	mm	mm	mm	LF1-3	mm	
36000	1360	1185	1360	130	295	272	2 x 30 x 1180	336	KB3136C1N1330
	1525	1260	1525					490	KB3153C1N1330
42000	1360	1185	1360	150	315	285	3 x 27 x 1190	336	KB3136C2N1532
	1525	1260	1525					490	KB3153C2N1532
42000	1360	1205	1360	150	385	359	3 x 27 x 1180	336	KB3136C3N1538
	1525	1285	1505					490	KB3153C3N1538

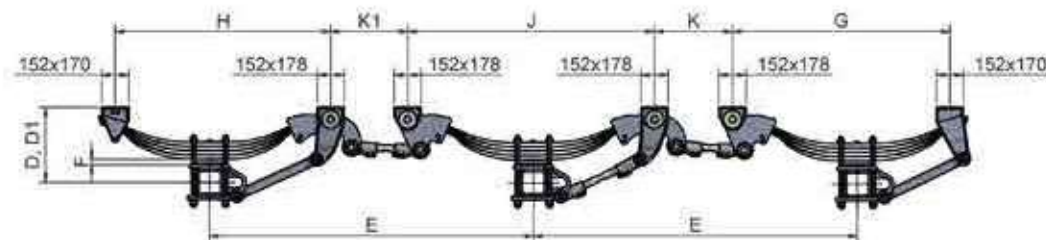

SENSO DI MARCIA  
FORWARD

### STANDARD

C	E	G	J	H	K	Q	D	D1	LF	CD
kg	mm	mm	mm	mm	mm	mm	mm	mm	LF1-3	
42000	1810	1215	1375	1195	435	150	315	285	3 x 27 x 1190	KB318AC2N1532
42000	1810	1215	1380	1195	435	150	385	359	3 x 27 x 1180	KB318AC3N1538

(F) Disponibili distanziali di 30mm per aumentare l'altezza di marcia (D, D1)  
(F) Available spacers of 30mm to increase the ride height (D, D1)  
(F) 30 mm Abstandstück verfügbar für Fahrhöhe vermehren (D, D1)

C = PORTATA / CAPACITY / TRAGFÄHIGKEIT

E = PASSO / WHEEL BASE / ACHSABSTAND

G = DISTANZA APPOGGI 1-3 / BRACKET DISTANCE 1-3 / AUFHÄNGUNGSABSTAND 1-3

J = DISTANZA APPOGGI 2 / BRACKET DISTANCE 2 / AUFHÄNGUNGSABSTAND 2

Q = TIPO ASSALE (LATO QUADRO) / AXLE TYPE (SQUARE BEAM) / ACHSENTYP (VKT)

D = ALTEZZA A VUOTO / HEIGHT WHEN EMPTY / BETRIEBSHÖHE-LEER

D1 = ALTEZZA SOTTO CARICO / HEIGHT LOADED / BETRIEBSHÖHE-BELADEN

LF1-3 = TIPO BALESTRA 1-3 / LEAF SPRING 1-3 / FEDERTYP 1-3

LF2 = TIPO BALESTRA 2 / LEAF SPRING 2 / FEDERTYP 2

EA = PASSO BILANCIERE / ROCKER LENGTH / LÄNGE AUSGLEICHWIEGE

CD = CODICE ORDINE / ORDER CODE / BESTELLN.R.

F = DISTANZIALE / SPACER / ABSTANDSTÜCK



## TANDEM "HEAVY-DUTY" CON BALESTRA PARABOLICA

"HEAVY-DUTY" TANDEM SUSPENSION WITH PARABOLIC SPRING  
 DOPPELACHSAGGREGAT "HEAVY-DUTY" MIT PARABELFEDERN

type **KW 100** mm wide

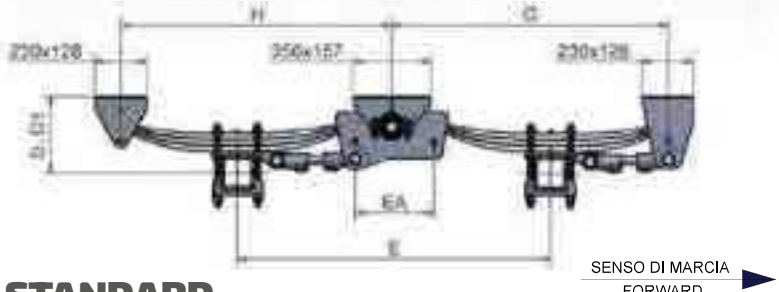

### STANDARD

C	E	G	H	J	EA	Q	D	D1	LF		CD
									LF1-3	LF2	
kg	mm	mm	mm	mm	mm	mm	mm	mm			
24 000	1410	1260	1220	-	355	130	330	307	2 x 30 x 1180	-	KW2141C1N1331
	1525	1298	1273	-	480	130					KW2153C1N1331
	1810	1445	1410	-	817	130					KW2181C1N1333
32 000	1410	1260	1220	-	355	150	350	320	3 x 27 x 1190	-	KW2141C2N1534
	1525	1298	1273	-	480	150					KW2153C2N1534
	1810	1445	1410	-	817	150					KW2181C2N1535

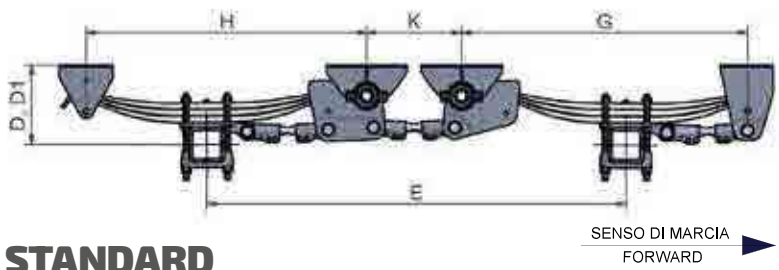

### STANDARD

C	E	G	H	J	K	Q	D	D1	LF		CD
									LF1-3	LF2	
kg	mm	mm	mm	mm	mm	mm	mm	mm			
32000	1810	1255	1220	-	380	150	355	325	3 x 27 x 1190	-	KW2180C2N1534
	1850				420						
32000	1860	1255	1220	-	380	150	355	325	3 x 27 x 1190	-	KW2190C2N1534
	1900				420						

- C = PORTATA / CAPACITY / TRAGFÄHIGKEIT
- E = PASSO / WHEEL BASE / ACHSABSTAND
- G = DISTANZA APPOGGI 1-3 / BRACKET DISTANCE 1-3 / AUFHÄNGUNGSABSTAND 1-3
- J = DISTANZA APPOGGI 2 / BRACKET DISTANCE 2 / AUFHÄNGUNGSABSTAND 2
- Q = TIPO ASSALE (LATO QUADRO) / AXLE TYPE (SQUARE BEAM) / ACHSENTYP (VKT)
- D = ALTEZZA A VUOTO / HEIGHT WHEN EMPTY / BETRIEBSHÖHE-LEER
- D1 = ALTEZZA SOTTO CARICO / HEIGHT LOADED / BETRIEBSHÖHE-BELADEN
- LF1-3 = TIPO BALESTRA 1-3 / LEAF SPRING 1-3 / FEDERTYP 1-3
- LF2 = TIPO BALESTRA 2 / LEAF SPRING 2 / FEDERTYP 2
- EA = PASSO BILANCIERE / ROCKER LENGTH / LÄNGE AUSGLEICHWIEGE
- CD = CODICE ORDINE / ORDER CODE / BESTELLN.R.
- F = DISTANZIALE / SPACER / ABSTANDSTÜCK

### TRIDEM "HEAVY-DUTY" CON BALESTRA PARABOLICA

"HEAVY-DUTY" TRI-AXLE SUSPENSION WITH PARABOLIC SPRING  
DREIACHSAGGREGAT „HEAVY-DUTY“ MIT PARABELFEDERN

type **KW** 100 mm wide

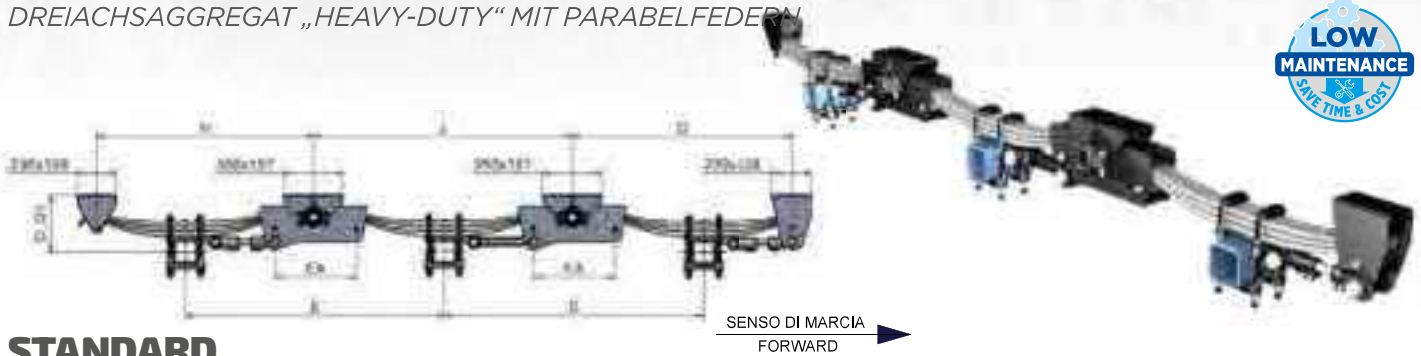

### STANDARD

C	E	G	H	J	EA	Q	D	D1	LF		CD
kg	mm	mm	mm	mm	mm	mm	mm	mm	LF1-3	LF2	
36 000	1410	1268	1220	1410	355	130	330	307	2 x 30 x 1180	-	KW3141C1N1331
	1525	1298	1273	1525	480	130					KW3153C1N1331
	1810	1445	1410	1810	817	130					KW3181C1N1333
48 000	1410	1260	1220	1410	355	150	350	320	3 x 27 x 1190	-	KW3141C2N1534
	1525	1298	1273	1525	480	150					KW3153C2N1534
	1810	1445	1410	1810	817	150					KW3181C2N1535

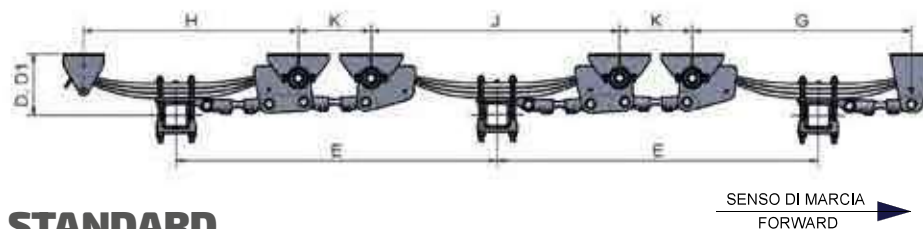

### STANDARD

C	E	G	H	J	K	Q	D	D1	LF		CD
kg	mm	mm	mm	mm	mm	mm	mm	mm	LF1-3	LF2	
48 000	1810	1260	1220	1440	370	150	350	320	3 x 27 x 1190	-	KW3180C2N1534
	410										
48 000	1860	1260	1220	1440	420	150	350	320	3 x 27 x 1190	-	KW3190C2N1534
	1900				460						

C = PORTATA / CAPACITY / TRAGFÄHIGKEIT

E = PASSO / WHEEL BASE / ACHSABSTAND

G = DISTANZA APPOGGI 1-3 / BRACKET DISTANCE 1-3 / AUFHÄNGUNGSABSTAND 1-3

J = DISTANZA APPOGGI 2 / BRACKET DISTANCE 2 / AUFHÄNGUNGSABSTAND 2

Q = TIPO ASSALE (LATO QUADRO) / AXLE TYPE (SQUARE BEAM) / ACHSENTYP (VKT)

D = ALTEZZA A VUOTO / HEIGHT WHEN EMPTY / BETRIEBSHÖHE-LEER

D1 = ALTEZZA SOTTO CARICO / HEIGHT LOADED / BETRIEBSHÖHE-BELADEN

LF1-3 = TIPO BALESTRA 1-3 / LEAF SPRING 1-3 / FEDERTYP 1-3

LF2 = TIPO BALESTRA 2 / LEAF SPRING 2 / FEDERTYP 2

EA = PASSO BILANCIERE / ROCKER LENGTH / LÄNGE AUSGLEICHWIEGE

CD = CODICE ORDINE / ORDER CODE / BESTELLN.R.

F = DISTANZIALE / SPACER / ABSTANDSTÜCK





## SOSPENSIONE "HEAVY-DUTY" CON BALESTRA PARABOLICA

"HEAVY-DUTY" SUSPENSION WITH PARABOLIC SPRING  
 "HEAVY-DUTY" SUSPENSION MIT PARABOLISCHER FEDER

type **KW 100** mm wide

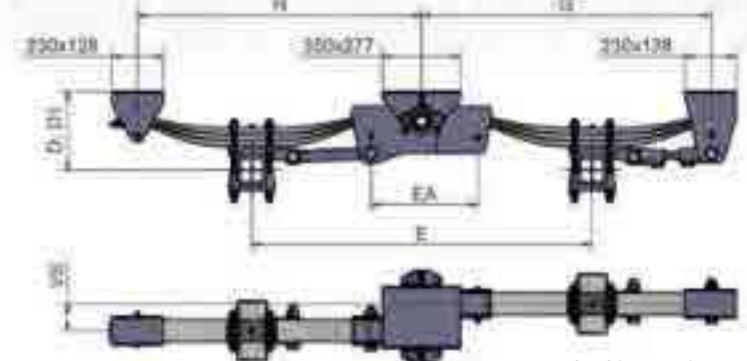

SENSO DI MARCIA FORWARD

### TANDEM - STANDARD

C	E	G	H	J	VS	EA	Q	D	D1	LF	CD
kg	mm	mm	mm	mm	mm	mm	mm	mm	mm	LF1-3	
24 000	1525	1298	1273	-	120	480	130	330	307	2 x 30 x 1180	KW2153C1N1331C01
32 000	1525	1298	1273	-	120	480	150	350	320	3 x 27 x 1190	KW2153C2N1534C01

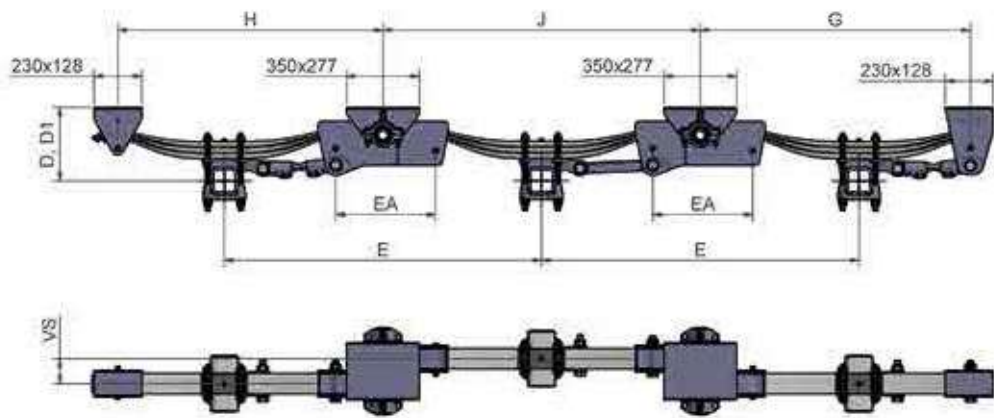

SENSO DI MARCIA FORWARD

### TRIDEM - STANDARD

C	E	G	H	J	VS	EA	Q	D	D1	LF	CD
kg	mm	mm	mm	mm	mm	mm	mm	mm	mm	LF1-3	
36 000	1525	1298	1273	1525	120	480	130	330	307	2 x 30 x 1180	KW3153C1N1331C01
48 000	1525	1298	1273	1525	120	480	150	350	320	3 x 27 x 1190	KW3153C2N1534C01

- C = PORTATA / CAPACITY / TRAGFÄHIGKEIT
- E = PASSO / WHEEL BASE / ACHSABSTAND
- G = DISTANZA APPOGGI 1-3 / BRACKET DISTANCE 1-3 / AUFHÄNGUNGSABSTAND 1-3
- J = DISTANZA APPOGGI 2 / BRACKET DISTANCE 2 / AUFHÄNGUNGSABSTAND 2
- Q = TIPO ASSALE (LATO QUADRO) / AXLE TYPE (SQUARE BEAM) / ACHSENTYP (VKT)
- D = ALTEZZA A VUOTO / HEIGHT WHEN EMPTY / BETRIEBSHÖHE-LEER
- D1 = ALTEZZA SOTTO CARICO / HEIGHT LOADED / BETRIEBSHÖHE-BELADEN
- LF1-3 = TIPO BALESTRA 1-3 / LEAF SPRING 1-3 / FEDERTYP1-3
- LF2 = TIPO BALESTRA 2 / LEAF SPRING 2 / FEDERTYP 2
- EA = PASSO BILANCIERE / ROCKER LENGTH / LÄNGE AUSGLEICHWIEGE
- CD = CODICE ORDINE / ORDER CODE / BESTELLN.R.
- F = DISTANZIALE / SPACER / ABSTANDSTÜCK